



Drake Landing Solar Community, Okotoks, Alberta, Canada

The first community in the world that is designed to have 90% of the annual heating load met by solar energy is now being built outside of Calgary.

Energy efficient homes combined with innovative methods of storing the solar energy during the sunny summer months, and utilizing the stored energy during the cold winter months, allow the community to achieve an unprecedented level of solar heating. With gas and electricity prices rising on an almost daily basis, home-owners in this new community can take comfort in knowing that they have done all they can to insulate themselves from high energy costs now and in the future.



The key to solar heating on large-scale projects like Drake Landing is to collect as much solar energy as is feasible; directly using the solar energy in the winter months when the demand for heat outweighs the supply from the solar collectors, and effectively storing the solar energy in the summer months (for use later in the season) when the supply from the collectors greatly outweighs the heating demand. The method of collecting excess



energy during the warm summer months for use during the winter months is referred to as seasonal storage. The solar energy collection is accomplished by using 800 flat-plate solar collectors (approximately 25,000 total square feet). The collectors are arrayed on a series of four specially-designed rows of connected garages located throughout the community; oriented south and angled up from the horizontal to maximize the collection of solar energy. During a typical summer day, the collectors can generate 1.5 megawatts of thermal power.

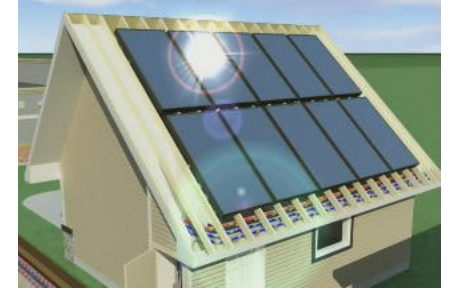

The trick with seasonal storage is to store the excess energy in such a way that the stored energy may be quickly and effectively removed from storage and supplied to the heating load; without losing too much of the energy to the environment (storage losses) and yet still retaining high enough temperatures to meet the heating loads of the buildings. To accomplish this task at Drake Landing, an innovative method utilizing both short-term, fluid-filled storage tanks and long-term ground-storage is employed. Two large water thermal storage tanks are located in an “Energy Center” at the edge of the community. Each of these tanks is approximately twelve and a half feet in diameter, 35 feet long, and contains around 30,000 gallons of water. They have been referred to as “mini-submarines” by the project team members due to their size.



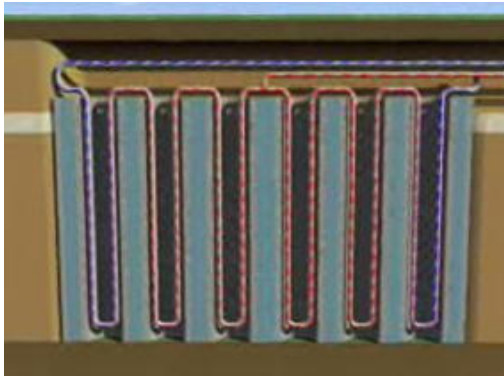

In this project, the ground underneath a park is used as the long-term storage device. One hundred and forty four holes, six inches in diameter, were drilled into the ground to a depth of approximately 115 feet. Into each of

these holes a plastic “U-tube” pipe is inserted which allows the water in the pipe to travel down the length of the hole, reverse direction, and return to the surface. The holes were then re-filled and connected together to form what is commonly referred to as a “Borehole thermal energy system” or BTES for short. The holes are connected in such a way as to promote radial stratification in the ground; thereby allowing the core of the ground volume to be at higher temperatures than the edges (desired for lower losses to the surrounding ground).

Even with insulation and proper control of the BTES, around one half of all energy delivered to the long term storage is lost to the surrounding soil and to the ambient during the year.

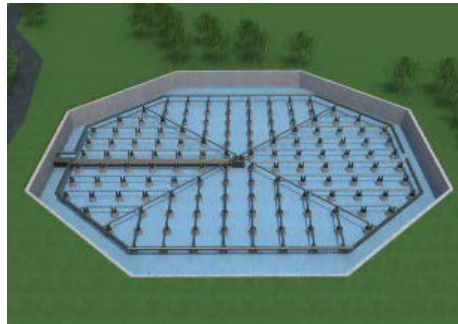

The water-filled storage tanks act as a buffer between the solar collectors and the building heating loads. During the summer months, the collectors charge the thermal storage tank with heated water by circulating water from the tanks through the solar collectors. Over the course of a day, cool water is removed from the storage tanks, heated by the collectors and returned to the storage tanks; thereby heating the tanks. When the tank temperatures rise beyond a pre-

determined limit, circulation pumps are activated and water travels from the storage tanks through the pipes in the ground (the long-term storage device) and back to the storage tanks; thereby heating the ground and cooling the storage tanks (which allows more solar energy to be collected). This process goes on throughout the summer and temperatures in the core of the ground storage may reach 175 degrees Fahrenheit.

During the heating season, hot water is circulated from the large storage tanks to each home in a district heating fashion. The hot water passes through specially-designed heat exchangers in each home and a high

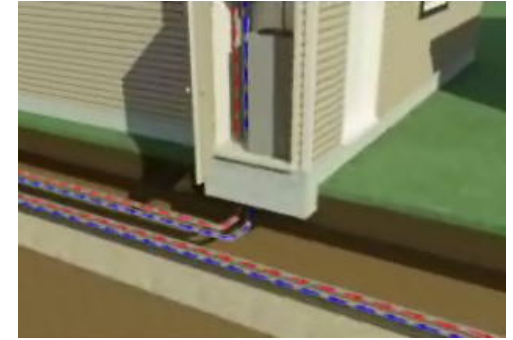

efficiency fan blows air across the heat exchangers; thereby heating the warm air which is then distributed throughout the home using traditional ductwork. The cool water leaving the homes is then returned to the storage tanks and the process repeats. On most days during the winter months, the solar collectors are not able to provide enough energy to the water storage tanks to heat the homes so energy is removed from the long term storage when needed by circulating cool water from the water storage tanks through the buried pipes in the long term storage. This process recovers some of the energy that has been stored in the ground and reheats the storage tanks; allowing heated water to then be removed to supply the house heating loads. A back-up gas boiler is provided to insure that heat is available to each and every home at all times during the heating season. During the spring and fall months most of the solar energy collected during the day is stored in the water tanks and circulation pumps provide each of the homes with a supply of hot water to meet

the heating load. Some charging and discharging of the long term storage does occur on particularly warm sunny or cool cloudy days.

In the first year of operation, the system is expected to provide only about 60% of the heating energy from collected solar energy with the remainder being provided by the natural gas boiler. This percentage should rise to over 90% by the end of 5 years (and stay at that level) as the ground is slowly heated up and the long-term storage becomes effective.

With a large innovative project like Drake Landing, one of the keys to the success of the project is the ability to accurately predict the performance of the system over the life of the project. Thermal Energy System Specialists LLC (TESS) of Madison, Wisconsin, USA was proud to have been chosen as the energy modeling firm for this exciting project. With a history of successful modeling projects in the solar energy and ground storage fields, and armed with a suite of state-of-the-art modeling and simulation tools, TESS was tasked with providing the design teams with predictions on the performance of the system over a wide range of operating and design considerations.

The project team consisted of individual experts in the fields of solar energy systems, ground heat exchanger design, thermal storage systems, district heating systems, controls, HVAC design, and building construction. Taking the ideas from each of these team member as to the “best” design for their subsystem (best collector layout, best size of the tanks, ideal control strategy etc.), and relying on an extremely flexible and powerful modeling tool called TRNSYS, TESS was able to construct a simulation model of the perceived “best” system. The simulation model was then capable of predicting the temperatures and energy flows in each component of the system (tanks, pipes, pump, heat

exchangers) on a one minute basis for 50 years of operation. Early simulation results revealed that the as-designed system was capable of providing 70-75 % of the heating energy with solar. Working closely with the controls experts, and by watching the temperatures and energy flows during the simulations, the controls were significantly re-worked and the performance crept closer to the 80% threshold. Using a powerful optimization routine, and keeping in mind the economic and project constraints (available funds, available land area, area available for solar collectors, etc.), the distribution of the number of solar collectors, the size of the short-term storage tanks, and the number and depth of the boreholes for the ground storage was varied to find the combination that maximized the performance of the system. Using 50 years of historical weather data as a basis, the simulation model is now predicting that the current design will provide an average of 90+% of the heating energy with solar. In some years the system is capable of providing 100% of the house heating loads with solar. It’s interesting to note that the “optimized system” is significantly different from the original expert choices for the components.

Time will tell how accurate these predictions are, but this project is far from over. Once construction is complete, detailed monitoring of the system will begin and this project takes on another exciting level. The current plan is to have TESS take the monitored data and calibrate the simulation model to the data. Once calibrated or “tuned”, the model will be able to more accurately predict the performance of the system in upcoming years. Variations in controls (setpoints, flow rates, operation etc.) can then be made using the simulation models first; with promising changes then carried out in the real system.



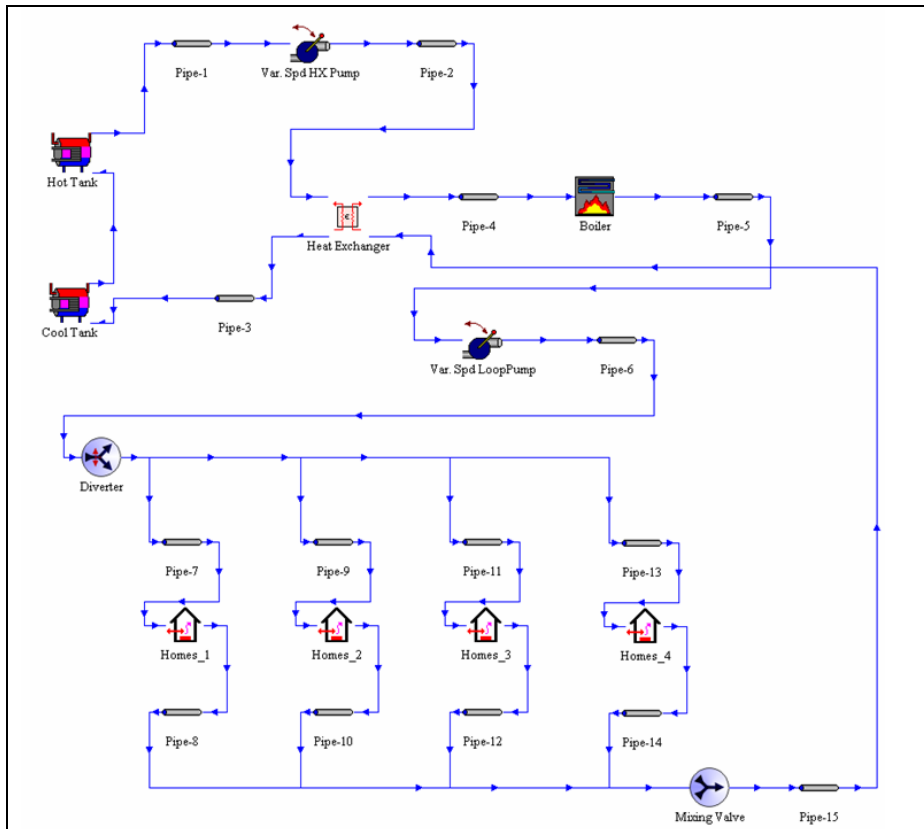

Figure 1: District Loop Layer in TRNSYS

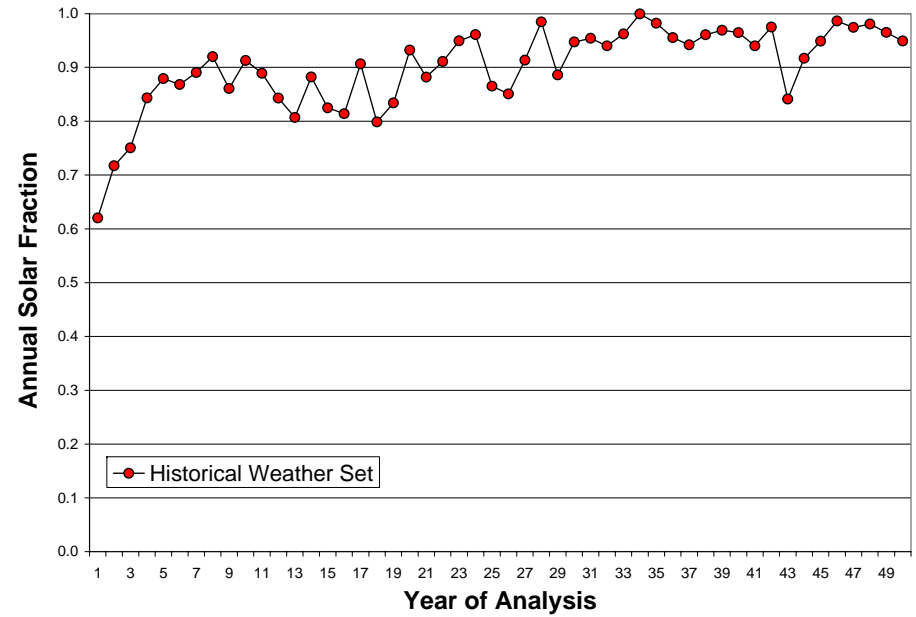

Figure 2: Results from 50-Year Simulation with Real Weather

Some of the images in this document are screen captures from the windows media file:
<http://www.sterlinghomesgroup.com/drake/images/drakelanding.wmv> provided by the Sterling Homes Corporation.